

A SECTION

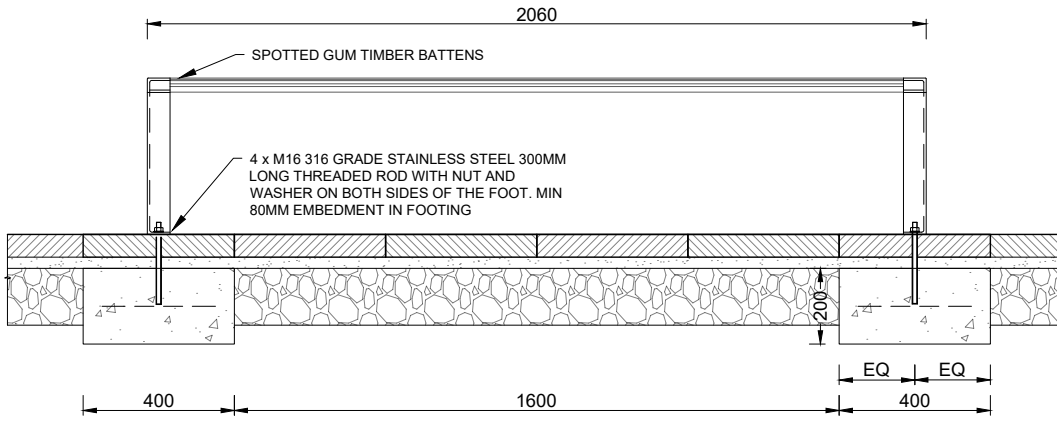

B FRONT ELEVATION

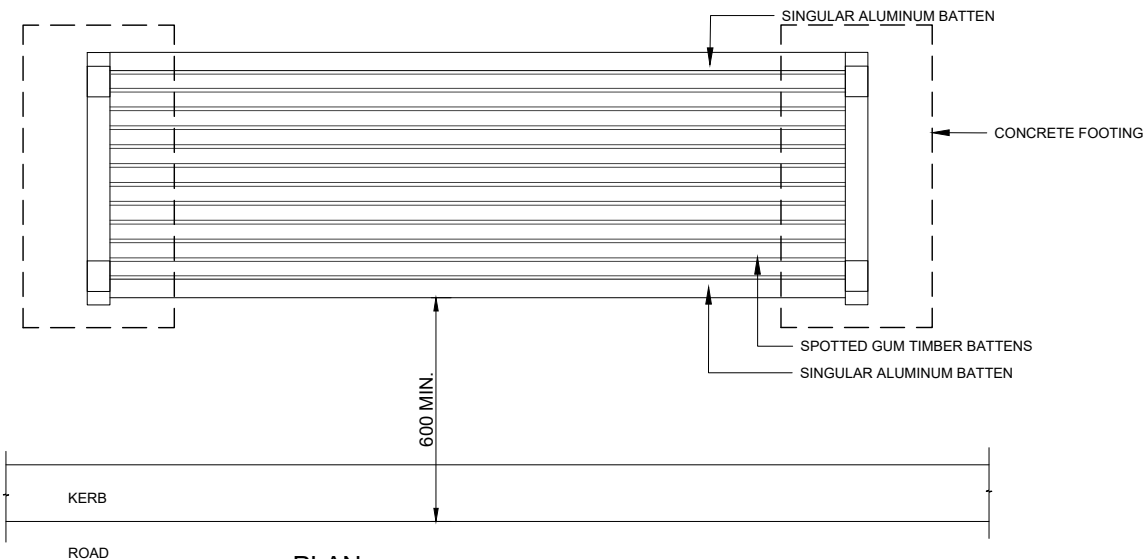

C PLAN



GENERAL NOTES:

CITY BENCHES SHOULD BE LOCATED TO ENSURE THAT THE FIXING DOWN BOLTS ARE 50MM MINIMUM FROM JOINTS IN THE PAVING.

SEATS SHOULD BE POSITIONED EITHER PARALLEL OR AT RIGHT ANGLES TO THE STREET AXIS. IN ADDITION, SEATS SHOULD BE LOCATED:

- * IN URBAN AREAS SUCH AS MALLS;
- * WHERE THEY ARE NEEDED;
- * WHERE THEY DO NOT BECOME OBSTRUCTIVE;
- * IN THE SHADE;
- * TO CREATE A SENSE OF SAFETY;
- * TO PROVIDE A VIEW TOWARDS ACTIVITIES;
- * A MINIMUM OF 600MM FROM THE FACE OF KERB.

THE FOOTING DESIGN IS ADEQUATE FOR ANY SITUATION WITH SUBGRADE SOIL THAT HAS A BEARING CAPACITY OF 50 KPA OR GREATER. SUBGRADE PREFERABLY IS A COMPACTED NATURAL MATERIAL OR COMPACTED SAND OR CRUSHED ROCK FILLING.

CITY OF PERTH SUPPLIER	
NAME/ COMPANY	DRAFFIN STREET FURNITURE
CONTACT DETAILS	EMAIL: info@draffin.com.au TEL: +61 3 9720 1033